

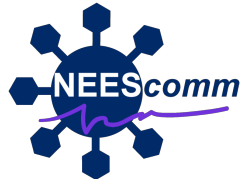

OpenSees

Open System for Earthquake Engineering Simulation  
Pacific Earthquake Engineering Research Center



# Modeling Diaphragms in 2D Models with Linear and Nonlinear Elements

*Vesna Terzic*  
*UC Berkeley*

October 2011

# Agenda

---

- Introduction to problem
- Consequences of applying a rigid constraint on a force-based beam-column element with different type of sections (demonstrated by an example)
- Conclusions and summary
- Q&A with web participants

# Introduction to the problem (1)

---

- Floor diaphragm need to be axially rigid to assure proper distribution of seismic forces to all lateral force resisting elements (columns and walls)
- Common modeling approach for frame structures is to represent the structural components (beams and columns) by line elements located at the original member centerlines and having cross-sectional properties equal to those of components
- Common way to model the effect of a rigid diaphragm at a floor level is by imposing rigid constraints on all nodes of that floor level and thus enforcing the same lateral displacements of all nodes at the floor level
- These constrains enforce condition of **zero axial strain on elements** that are part of that floor level

# Introduction to the problem (2)

---

- For sections where the neutral axis does not shift as a consequence of bending in the beam, axial strains at element's centerlines are zero, and thus rigid constraints can be applied to model a rigid diaphragm (e.g. steel sections, elastic materials)
- For nonlinear-beam column elements with RC fiber section where the neutral axis shifts due to bending in the beam axial strains at element's centerlines are no longer zero. Thus, rigid constraints that enforce condition of zero axial strain on elements will change the response of the frame

# Case study

---

- The effect of rigid constraints on a **force-based beam-column element** will be demonstrated on a portal frame considering three different types of sections:
  - Elastic steel section
  - Nonlinear steel section
  - Nonlinear concrete section
- Force-based beam-column element is chosen for this case study as it is the most widely used for modeling frame elements. However, all of conclusions derived from this study hold for displacement-based beam-column element.

# Example: portal frame

Two types of analysis:

- Pushover (up to displacement of 5 in.)
- Time history analysis

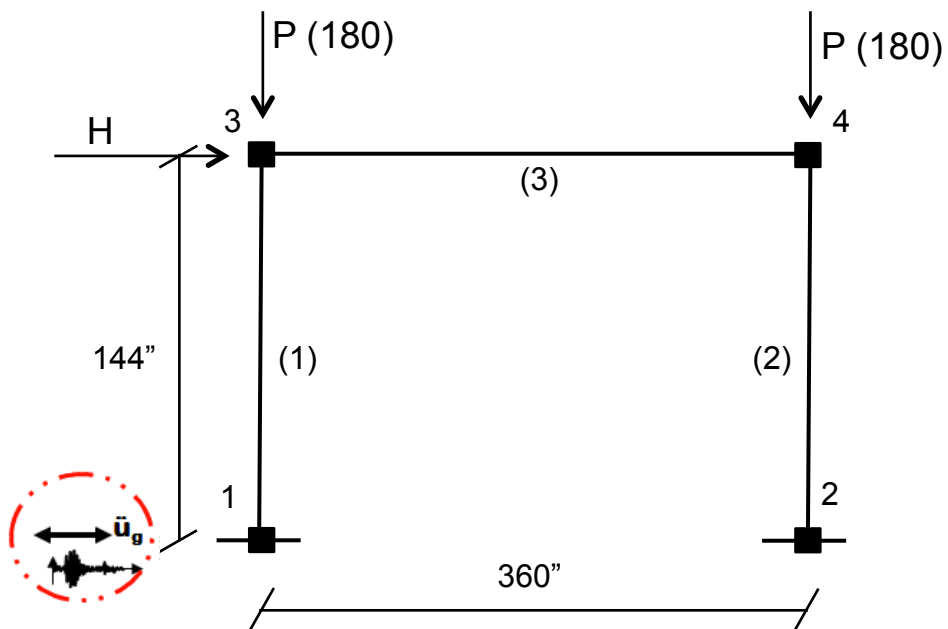

## *RC sections*

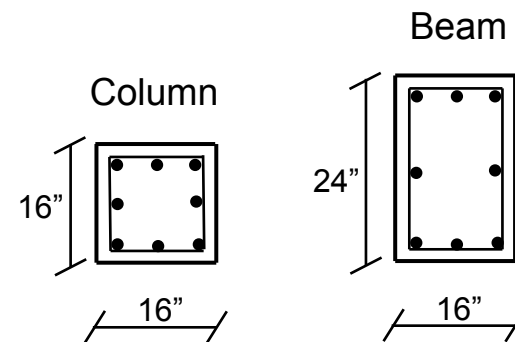

## *Steel sections*

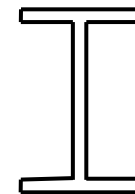

Column: W14x257

Beam: W24x68

# Materials

- Elastic steel section: Elastic material
- Nonlinear steel section: Steel02 material
- Nonlinear concrete section: Concrete01 for core and cover and Steel02 for reinforcement

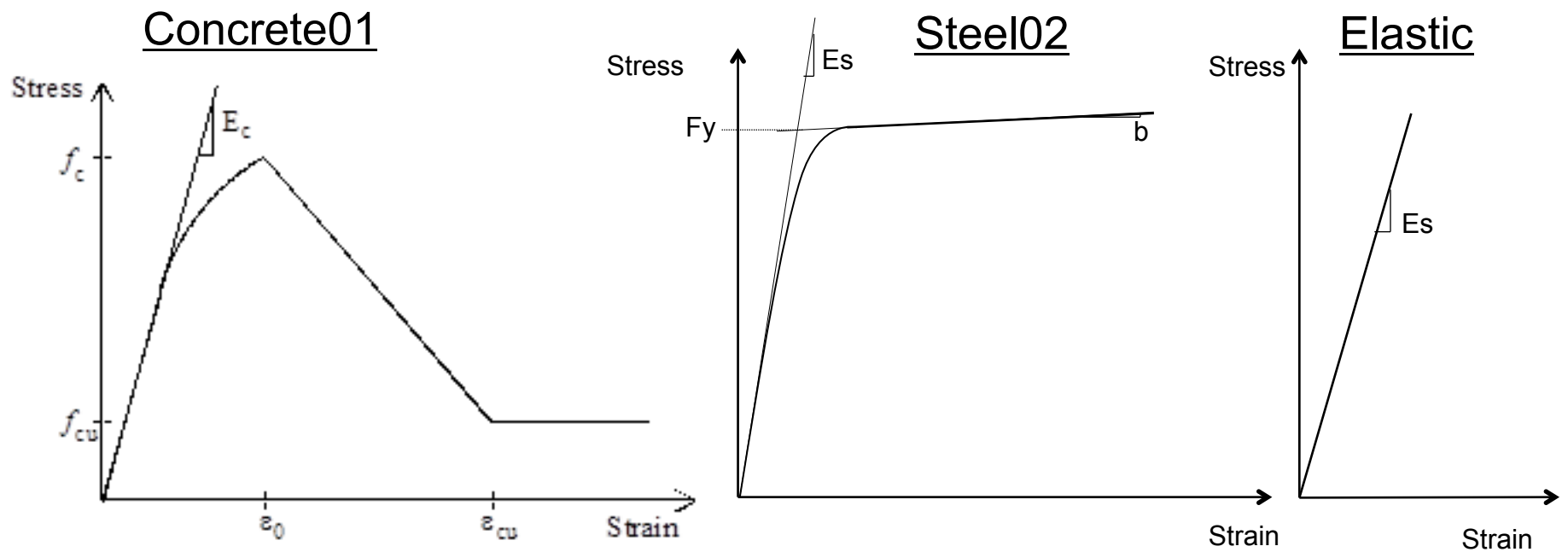

# Constraints

- The rigid constraints are imposed using “equalDOF” command in OpenSees

#	<i>\$masterNode</i>	<i>\$slaveNode</i>	<i>\$dof</i>
<i>equalDOF</i>	3	4	1

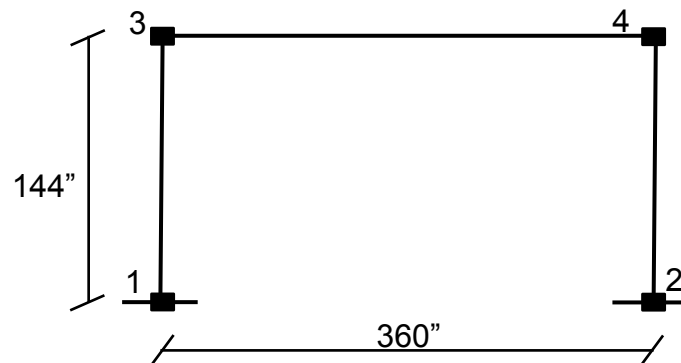



# Elastic steel fiber cross-section: Load at nodes 3 and 4

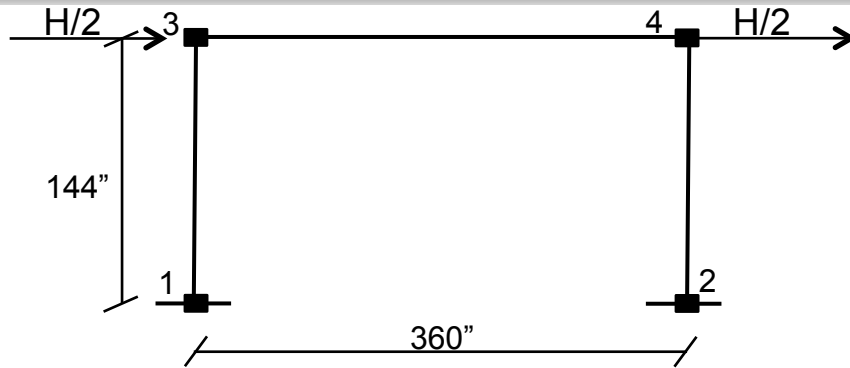

```
timeSeries Linear 1
pattern Plain 2 1 {
    load 3 1.0 0.0 0.0
    load 4 1.0 0.0 0.0
}
```

*Maximum displacement: 5.0 in*

Constraints	Axial deformation of the beam	Axial force in the beam	Bending moments in the beam		Shear forces in the columns	
No	0.0	0.0	34293	34293	852.17	852.17
Yes	0.0	0.0	34293	34293	852.17	852.17

# Elastic steel fiber cross-section: Load at node 3

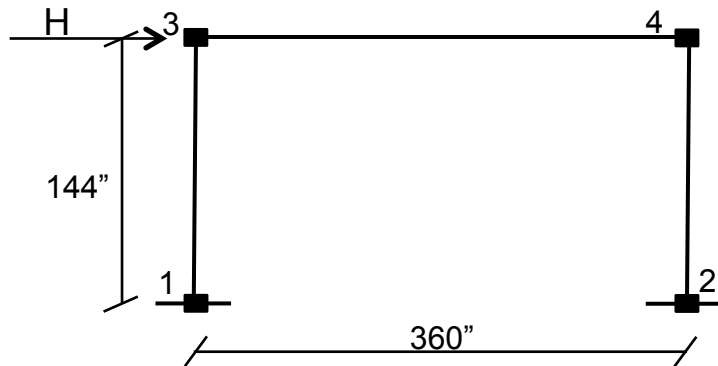

```
timeSeries Linear 1
pattern Plain 2 1 {
    load 3 1.0 0.0 0.0
}
```

*Maximum displacement: 5.0 in*

Constraints	Axial deformation of the beam	Axial force in the beam	Bending moments in the beam		Shear forces in the columns	
No	-0.487	779.5	33285	31955	841.7	779.5
Yes	0.0	0.0	34293	34293	852.17	852.17

# Elastic steel fiber cross-section: Time history analysis

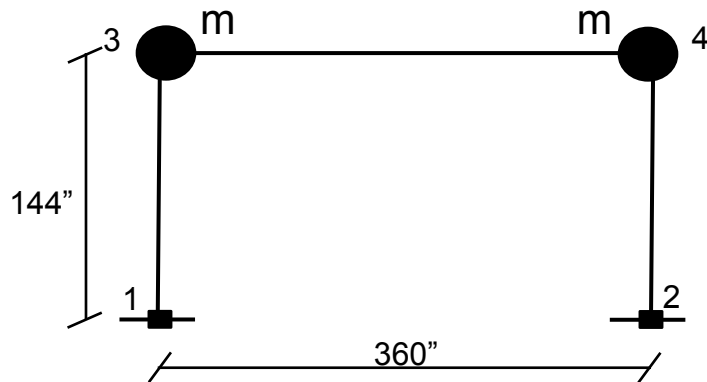

```
timeSeries Path 2 -dt 0.005 -filePath A10000.acc -factor $G
pattern UniformExcitation 2 1 -accel 2
```

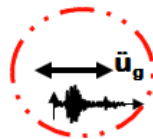

*Maximum displacement: 5.3 in*

Constraints	Axial deformation of the beam	Axial force in the beam	Bending moments in the beam		Shear forces in the columns	
No	0.0	0.0	36263	36263	901.13	901.13
Yes	0.0	0.0	36263	36263	901.13	901.13

# Nonlinear steel fiber cross-section: Load at nodes 3 and 4

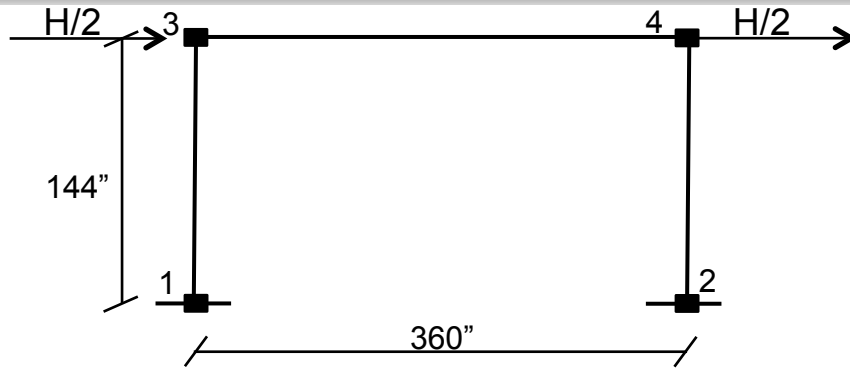

```
timeSeries Linear 1
pattern Plain 2 1 {
    load 3 1.0 0.0 0.0
    load 4 1.0 0.0 0.0
}
```

*Maximum displacement: 5.0 in*

Constraints	Axial deformation of the beam	Axial force in the beam	Bending moments in the beam		Shear forces in the columns	
No	0.00039	0.237	11131	11131	300.29	299.82
Yes	0.0	0.0	11131	11131	300.29	299.82

# Nonlinear steel fiber cross-section: Load at node 3

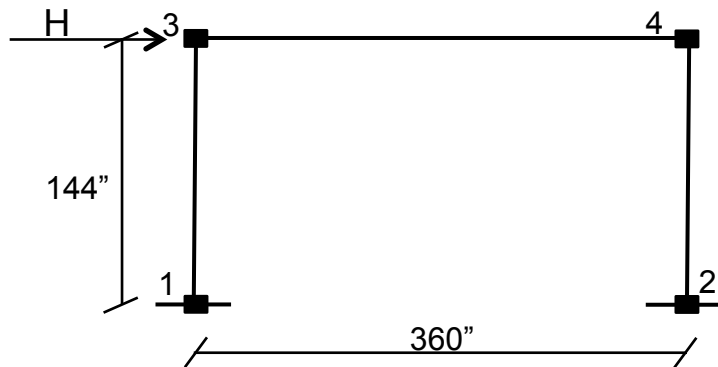

```
timeSeries Linear 1
pattern Plain 2 1 {
    load 3 1.0 0.0 0.0
}
```

*Maximum displacement: 5.0 in*

Constraints	Axial deformation of the beam	Axial force in the beam	Bending moments in the beam		Shear forces in the columns	
No	-0.44	292	10527	10424	296	292
Yes	0.0	0.0	11131	11131	300.29	299.82

# Nonlinear steel fiber cross-section: Time history analysis

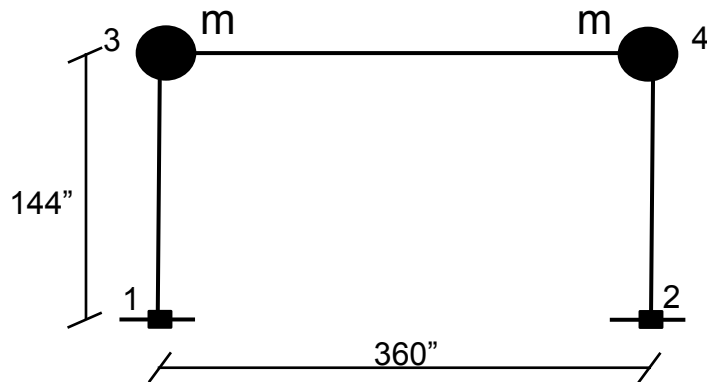

```
timeSeries Path 2 -dt 0.005 -filePath A10000.acc -factor $G
pattern UniformExcitation 2 1 -accel 2
```

*Maximum displacement: 4.0 in*

Constraints	Axial deformation of the beam	Axial force in the beam	Bending moments in the beam		Shear forces in the columns	
No	0.000614531	0.67	10679	10679	284.93	284.93
Yes	0.0	0.0	10679	10679	284.93	284.93

# Nonlinear RC fiber cross-section: Load at nodes 3 and 4

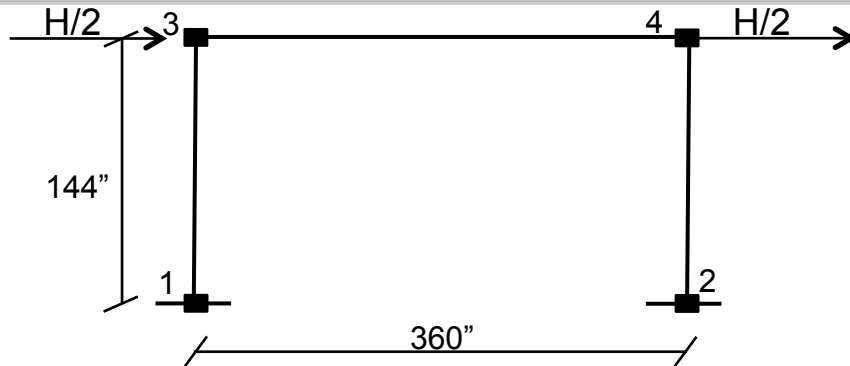

```
timeSeries Linear 1
pattern Plain 2 1 {
    load 3 1.0 0.0 0.0
    load 4 1.0 0.0 0.0
}
```

*Maximum displacement: 5.0 in*

Constraints	Axial deformation of the beam	Axial force in the beam	Bending moments in the beam		Shear forces in the columns	
<b>No</b>	0.154	0.081	2634.1	2622.0	36.02	35.86
<b>Yes</b>	0.0	140.9	2575.9	2575.7	35.62	35.57

# Nonlinear RC cross-section: Load at nodes 3 and 4



```
timeSeries Linear 1
pattern Plain 2 1 {
    load 3 1.0 0.0 0.0
    load 4 1.0 0.0 0.0
}
```

*All elements have the same cross-section*

Constraints	Axial deformation of the beam	Axial force in the beam	Bending moments in the beam		Shear forces in the columns	
No	0.669	0.738	3395.6	3445.4	56.62	58.10
Yes	0.0	272.72	4723.0	4888.0	65.69	67.98



# Nonlinear RC fiber cross-section: Load at node 3

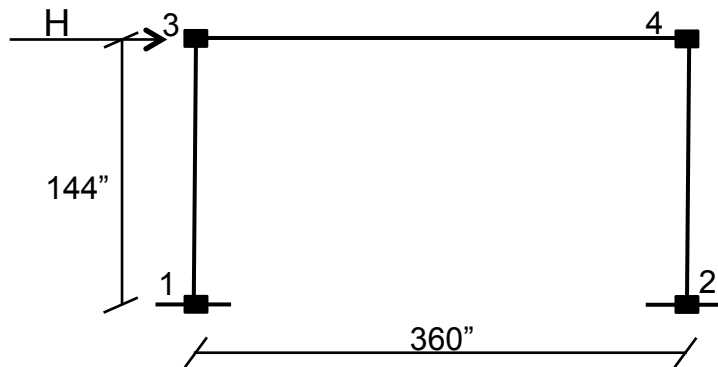

```
timeSeries Linear 1
pattern Plain 2 1 {
    load 3 1.0 0.0 0.0
}
```

*Maximum displacement: 5.0 in*

Constraints	Axial deformation of the beam	Axial force in the beam	Bending moments in the beam		Shear forces in the columns	
No	0.095	35.65	2616.4	2587.2	35.9	35.64
Yes	0.0	140.9	2575.9	2575.7	35.62	35.57

# Nonlinear RC fiber cross-section: Time history analysis

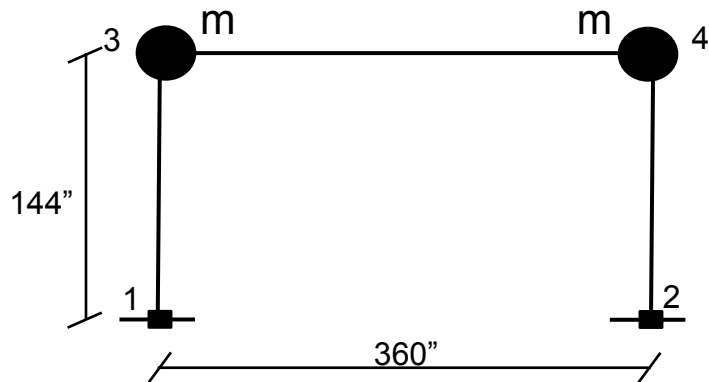

```
timeSeries Path 2 -dt 0.005 -filePath A10000.acc -factor $G
pattern UniformExcitation 2 1 -accel 2
```

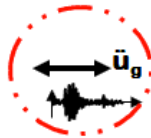

Constr.	Max. disp at nodes 3 & 4	Axial deformation of the beam	Axial force in the beam	Bending moments in the beam		Shear forces in the columns	
No	4.36 4.20	0.172	47.3	2798.3	2826.3	37.81	38.49
Yes	4.02	0.0	153.60	2765.8	2837.6	37.47	38.58

# Nonlinear RC fiber cross-section: Time history analysis

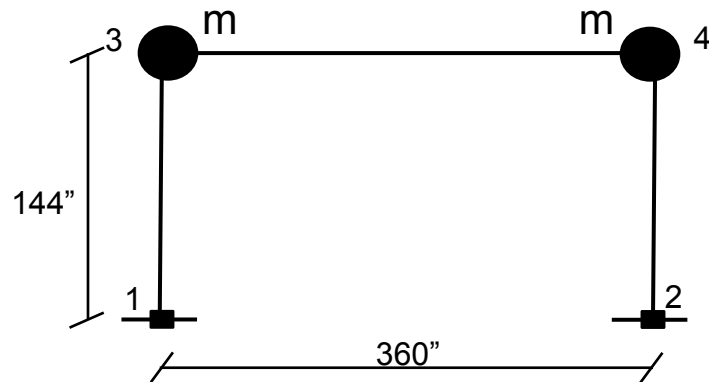

```
timeSeries Path 2 -dt 0.005 -filePath A10000.acc -factor $G
pattern UniformExcitation 2 1 -accel 2
```

*All elements have the same cross-section*

Constr.	Max. disp at nodes 3 & 4	Axial deformation of the beam	Axial force in the beam	Bending moments in the beam		Shear forces in the columns	
No	5.5 4.9	0.71	55.1476	3397.9	3359.2	57.08	56.01
Yes	3.8	0.0	271.50	4946.58	4643.93	68.26	64.87

# Summary and conclusions

---

- To model the effect of a diaphragm on a 2D frame rigid constraints can be used for elastic and steel elements
- Presence of rigid constraints in concrete nonlinear elements will induce unrealistic axial force and possibly change bending moments in the beam and shear forces in the columns.
- Concrete elements have very high axial stiffness (solid sections) and as such may be capable of transferring the seismic forces to the columns. However, this has to be checked for each specific model.

# Questions?

---